

2606B System SourceMeter® SMU Instrument

Datasheet



The 2606B System SourceMeter Source Measure Unit (SMU) Instrument offers four 20-watt SMU channels in a 1U high form factor chassis. Built from Keithley's third generation SMU technology, the 2606B offers the combined capabilities of a precision power supply, true current source, 6½-digit DMM, arbitrary waveform generator, and pulse generator—all into one tightly-integrated instrument. The result is a powerful solution that significantly boosts productivity for demanding automated qualification and production testing for optoelectronic devices such as VCSELs/laser diodes used in 3D sensing, telecommunication, and LEDs used in consumer products and automobiles, as well as integrated devices like analog ICs, ASICs, and system-on-a-chip (SOC) devices. When a high SMU channel count is required, multiple 2606B units can be stacked on top of each other without the need for thermal spacing between units. Built-in web browser-based software enables communicating to the 2606B through any computer from anywhere in the world. For automated system applications, the 2606B's Test Script Processor (TSP®) technology runs complete test programs from inside the instrument for industry-best throughput. In larger, multi-channel applications, Keithley's TSP-Link® technology works together with TSP technology to enable high-speed, SMU-per-pin parallel testing. Each 2606B SMU is code compatible with the industry leading Keithley 2602B System SourceMeter SMU Instrument when you are using the new ranges.

Key Features

- Four-channel SMU instrument in a single 1U full rack chassis
- Stackable; no 1U spacing requirements between units
- Tightly-integrated voltage/current source and measure instruments offer best in class performance with 6½-digit resolution
- 20 V @ 1 A and 6 V @ 3 A power envelopes, 20 watts
- 0.015% DCV basic accuracy
- Up to 28 open drain digital I/O bits
- Correlated results to the 2602B System SourceMeter SMU Instrument
- TSP technology embeds complete test programs inside the instrument for best-in-class system-level throughput
- TSP-Link expansion technology for multi-channel parallel test without a mainframe
- Front Panel LAN (LXI-C), USB 2.0 TMC488 protocol, and digital I/O interfaces
- Built-in web browser based software enables remote control through any browser, on any computer from anywhere in the world

Unmatched Throughput for Automated Test with TSP Technology

For test applications that demand the highest levels of automation and throughput, the 2606B's TSP technology delivers industry-best performance. TSP technology goes far beyond traditional test command sequencers – it fully embeds then executes complete test programs from within the SMU instrument itself. This virtually eliminates time-consuming bus communications to and from the PC controller and thus dramatically improves overall test times.

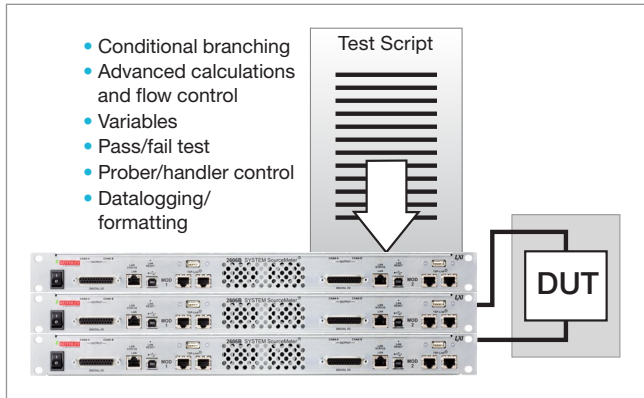

TSP technology executes complete test programs from the 2606B's non-volatile memory.

SMU-Per-Pin Parallel Testing with TSP-Link Technology

TSP-Link is a channel expansion bus that enables multiple Series 2606B's to be inter-connected or connected with other Keithley TSP-enabled instruments and function as a single, tightly-synchronized, multi-channel system. The 2606B's TSP-Link Technology works together with its TSP technology to enable high-speed, SMU-per-pin parallel testing. Unlike other high-speed solutions such as large ATE systems, the 2606B achieves parallel test performance without the cost or burden of a mainframe. The TSP-Link based system also enables superior flexibility, allowing for quick and easy system re-configuration as test requirements change.

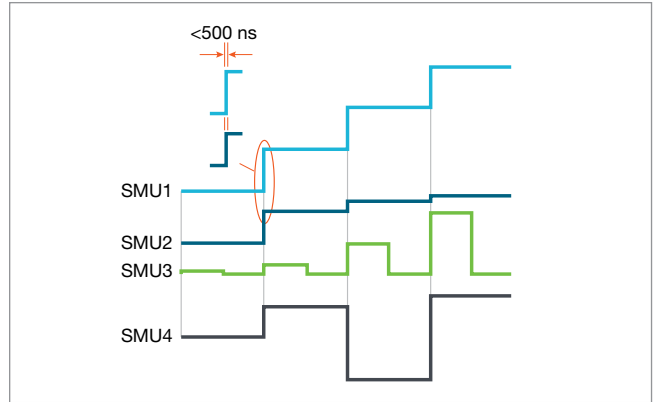

All channels in the TSP-Link system are synchronized to under 500 ns.

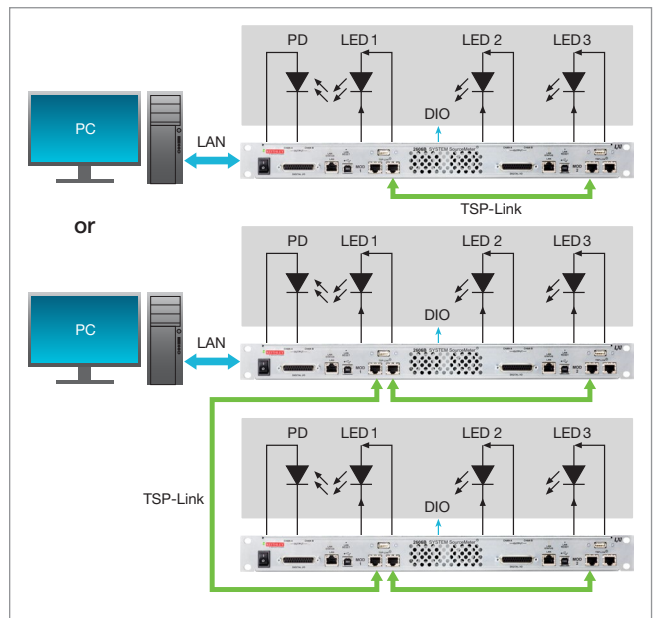

SMU-per-pin parallel or multi-pin device testing using TSP and TSP-Link technologies improves test throughput and lowers the cost of test.

2606B Front Panel

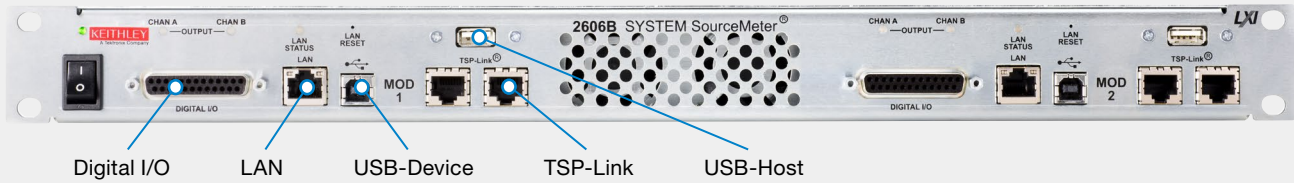

Digital I/O LAN USB-Device TSP-Link USB-Host

2606B Rear Panel

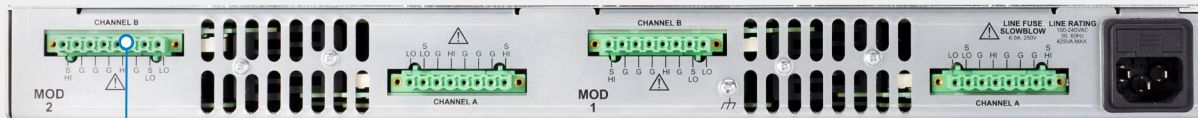

Analog I/O



2606B SMU instruments are easily racked and stacked in a rack system with minimum rail depth of 27 inches (0.686 m).

Third-generation SMU Instrument Design Ensures Faster Test Times

Based on the proven architecture of the Series 2600B instruments, the 2606B's SMU instrument design enhances test speed in several ways. For example, the 2606B uses a patented series ranging topology that provides faster and smoother range changes and outputs that settle more quickly.

The 2606B SMU instrument design supports two modes of operation for use with a variety of loads. In normal mode, the SMU instrument provides high bandwidth performance for maximum throughput. In high capacitance (high-C) mode, the SMU instrument uses a slower bandwidth to provide robust performance with higher capacitive loads.

Typical Applications

I-V functional test and characterization of a wide range of devices, including:

- Optoelectronic devices
 - Vertical cavity surface emitting lasers (VCSELs), laser diodes (used on 3D sensing systems)
 - High brightness (HBLEDs), light-emitting diodes (LEDs)
 - Displays
- Integrated devices small scale integrated (SSI) and large scale integrated (LSI)
 - Analog ICs
 - Radio frequency integrated circuits (RFICs)
 - Application specific integrated circuits (ASICs)
 - System on a chip (SOC) devices
- Discrete and passive components
 - Two-leaded sensors, disk drive heads, metal oxide varistors (MOVs), diodes, zener diodes, sensors, capacitors, thermistors
 - Three-leaded small signal bipolar junction transistors (BJTs), field-effect transistors (FETs), and more
- Simple ICs optos, drivers, switches, sensors, converters, regulators



Specification Conditions

This document contains specifications and supplemental information for the 2606B System SourceMeter® instrument. Specifications are the standards against which the 2606B instruments are tested. Upon leaving the factory, the 2606B instruments meet these specifications. Supplemental and typical values are nonwarranted, apply at 23°C, and are provided solely as useful information. Specifications are for individual modules.

Source and measurement accuracies are specified at the 2606B terminals under these conditions:

1. 23°C ±5°C, <70 percent relative humidity
2. After a two-hour warm-up period
3. Speed normal (1 NPLC)
4. A/D autozero enabled
5. Remote sense operation or properly zeroed local operation
6. Calibration period: One year

DC Power Specifications

	Voltage	Current
Maximum output power and source limits ^{1, 2}	20.2 W maximum 20.2 V at 1.0 A, -20.2 V at -1.0 A 6.06 V at 3.0 A, -6.06 V at -3.0 A	20.2 W maximum 1.01 A at 20 V, -1.01 A at -20 V 3.03 A at 6 V, -3.03 A at -6 V

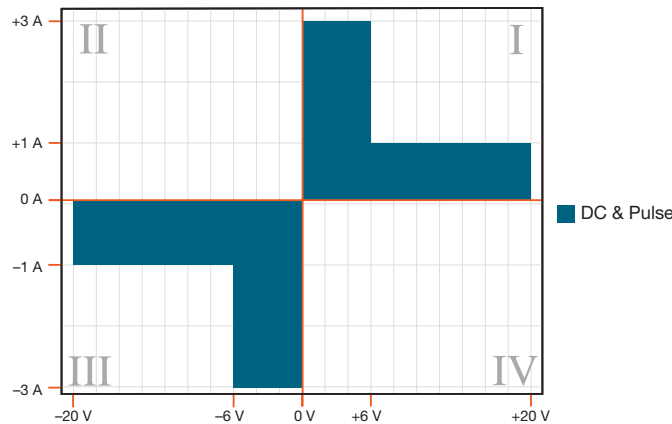

Voltage Accuracy Specifications ^{3, 4}

Range	Source			Measure	
	Programming Resolution	Accuracy ±(% reading + volts)	Typical Noise (peak to peak) 0.1 Hz to 10 Hz	Display Resolution	Accuracy ±(% reading + volts)
100 mV	5 µV	0.02% + 250 µV	20 µV	100 nV	0.015% + 150 µV
1 V	50 µV	0.02% + 400 µV	50 µV	1 µV	0.015% + 200 µV
6 V	50 µV	0.02% + 1.8 mV	100 µV	1 µV	0.015% + 1 mV
20 V	500 µV	0.02% + 12 mV	500 µV	10 µV	0.015% + 8 mV

Notes

1. For additional power derating information for various load and temperature conditions, refer to "Operating Boundaries" in the Series 2606B Reference Manual.
2. The System SourceMeter® will allow quadrant II and quadrant IV operation, however, it is intended for low power or short transient behavior. Operation in quadrant II and quadrant IV could result in an overtemperature error.
3. For temperatures 0°C to 18°C and 28°C to 50°C, accuracy is degraded by ±(0.15 × accuracy specification)/°C.
4. Add 50 µV to source accuracy specifications per volt of HI lead drop.

Current Accuracy Specifications ³

Range	Source			Measure	
	Programming Resolution	Accuracy ±(% reading + amperes)	Typical Noise (peak to peak) 0.1 Hz to 10 Hz	Display Resolution	Accuracy ⁵ ± (% reading + amperes)
100 nA	2 pA	0.06% + 100 pA	5 pA	100 fA	0.05% + 100 pA
1 μA	20 pA	0.03% + 800 pA	25 pA	1 pA	0.025% + 500 pA
10 μA	200 pA	0.03% + 5 nA	60 pA	10 pA	0.025% + 1.5 nA
100 μA	2 nA	0.03% + 60 nA	3 nA	100 pA	0.02% + 25 nA
1 mA	20 nA	0.03% + 300 nA	6 nA	1 nA	0.02% + 200 nA
10 mA	200 nA	0.03% + 6 μA	250 nA	10 nA	0.02% + 2.5 μA
100 mA	2 μA	0.03% + 30 μA	600 nA	100 nA	0.02% + 20 μA
1 A	20 μA	0.05% + 1.8 mA	70 μA	1 μA	0.03% + 1.5 mA
3 A	20 μA	0.06% + 4 mA	150 μA	1 μA	0.05% + 3.5 mA

Supplemental Characteristics

The following specifications are supplemental characteristics that provide additional information about instrument functions and performance. These characteristics are nonwarranted specifications; they describe the typical performance of the 2606B.

Additional Source Characteristics

Noise 10 Hz to 20 MHz < 20 mV peak-peak, < 3 mV RMS, 6 V range

Minimum Programmable Pulse Width ^{6, 7}
100 μs

Note: Minimum pulse width for settled source at a given I/V output and load can be longer than 100 ms.

Source value	Load	Source settling time (% of range)	Minimum pulse width
6 V	2 Ω	0.2%	150 μs
3 A	2 Ω	0.2%	150 μs

Notes

- For temperatures 0°C to 18°C and 28°C to 50°C, accuracy is degraded by $\pm(0.15 \times \text{accuracy specification})/^\circ\text{C}$.
- Derate accuracy specification for NPLC setting <1 by increasing the error term. Add appropriate typical percent of reading term for resistive loads using the table below.

NPLC Setting	200 mV Range	2 V–200 V Ranges	100 nA Range	1 μA–100 mA Ranges	1 A–1.5 A Ranges
0.1	0.01%	0.01%	0.01%	0.01%	0.01%
0.01	0.08%	0.07%	0.1%	0.05%	0.05%
0.001	0.8%	0.6%	1%	0.5%	1.1%

- Times measured from the start of pulse to the start off-time; see figure below.

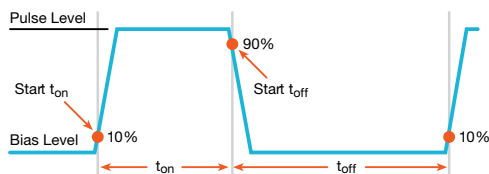

- With source settling set to SETTLE_SMOOTH_100NA

Pulse Width Programming Resolution

1 μs

Pulse Width Programming Accuracy	$\pm 5 \mu\text{s}$
Pulse Width Jitter	2 μs
Transient Response Time	<70 μs for the output to recover to within 0.1% for a 10% to 90% step change in load.
Overshoot	<p>Voltage: $<\pm 0.1\%$ of range + 10 mV. Step size = 10% to 90% of range, resistive load, maximum current limit/compliance</p> <p>Current: $<\pm 0.1\%$ of range. Step size = 10% to 90% of range, resistive load. See Current Source Output Settling Time for additional test conditions.</p>
Range Change Overshoot	<p>Voltage: $<300 \text{ mV} + 0.1\%$ of larger range. Overshoot into a 100 kΩ load, 20 MHz bandwidth.</p> <p>Current⁷: $<300 \text{ mV}/R_{\text{LOAD}} + 5\%$ of larger range</p>
Guard Offset Voltage	<4 mV, current <10 mA
Remote Sense Operating Range⁸	<p>Maximum voltage between HI and SENSE HI = 3 V</p> <p>Maximum voltage between LO and SENSE LO = 3 V</p>
Voltage Output Headroom	<p>20 V Range: Maximum output voltage = 22 V – (total voltage drop across source leads). Maximum 1 Ω source lead.</p> <p>6 V Range: Maximum output voltage = 8 V – (total voltage drop across source leads). Maximum 1 Ω source lead.</p>
Overtemperature Protection	Internally sensed temperature overload puts the instrument in standby mode
Limit/Compliance	<p>Bipolar limit (compliance) set with a single value.</p> <p>Voltage: Minimum value is 10 mV; accuracy is the same as voltage source.</p> <p>Current: Minimum value is 10 nA; accuracy is the same as current source</p>

Voltage Source Output Settling Time
 Time required to reach within 0.1% of final value after source level command is processed on a fixed range.

Voltage Range	Settling Time
100 mV	< 50 μs
1 V	< 50 μs
10 V	< 110 μs
20 V ⁹	< 150 μs

Current Source Output Settling Time
 Time required to reach within 0.1% of final value after source level command is processed on a fixed range. Values below for $I_{\text{OUT}} \times R_{\text{LOAD}} = 1 \text{ V}$

Current Range	Settling Time
3 A	< 80 μs (Current < 2.5 A, $R_{\text{LOAD}} > 2 \Omega$)
1 A to 10 mA	< 80 μs ($R_{\text{LOAD}} > 6 \Omega$)
1 mA	< 100 μs
100 μA	< 150 μs
10 μA	< 500 μs
1 μA	< 2 ms
100 nA	< 20 ms

Notes

- 7. With source settling set to SETTLE_SMOOTH_100NA
- 8. Add 50 μV to source accuracy specifications per volt of HI lead drop.
- 9. Add 150 μs when measuring on the 1 A range.

Additional Measurement Characteristics

Current Measure Settling Time¹⁰ Time required to reach within 0.1% of final value after source level command is processed on a fixed range. Values below for $V_{out} = 1\text{ V}$

Current Range	Settling Time
1 mA	< 100 μs

Input Impedance > 10 $\text{G}\Omega$

Additional Characteristics

Maximum load impedance Normal mode 10 nF. High capacitance mode 50 μF .

Common Mode Voltage 250 VDC

Common Mode Isolation >1 $\text{G}\Omega$, < 4500 pF

Sense High Input Impedance >10 $\text{G}\Omega$

Maximum Sense Lead Resistance 1 k Ω for rated accuracy

Overrange 101% of source range. 102% of measure range.

Measurement Speed Characteristics^{11, 12}

Maximum Sweep Operations Rates (operations per second) for 60 Hz (50 Hz)

A/D Converter Speed (NPLC)	Trigger Origin	Measure to Memory (using user scripts)	Measure to USB (using user scripts)	Source Measure to Memory (using user scripts)	Source Measure to USB (using user scripts)	Source Measure to Memory (using sweep API)	Source Measure to USB (using sweep API)
0.001	Internal	20000 (20000)	9800 (9800)	7000 (7000)	6200 (6200)	12000 (12000)	5900 (5900)
0.001	Digital I/O	8100 (8100)	7100 (7100)	5500 (5500)	5100 (5100)	11200 (11200)	5700 (5700)
0.01	Internal	4900 (4000)	3900 (3400)	3400 (3000)	3200 (2900)	4200 (3700)	4000 (3500)
0.01	Digital I/O	3500 (3100)	3400 (3000)	3000 (2700)	2900 (2600)	4150 (3650)	3800 (3400)
0.1	Internal	580 (480)	560 (470)	550 (465)	550 (460)	560 (470)	545 (460)
0.1	Digital I/O	550 (460)	550 (460)	540 (450)	540 (450)	560 (470)	545 (460)
1.0	Internal	59 (49)	59 (49)	59 (49)	59 (49)	59 (49)	59 (49)
1.0	Digital I/O	59 (49)	59 (49)	59 (49)	59 (49)	59 (49)	59 (49)

Notes

10. Compliance equal to 100 mA.

11. Tests performed using the following equipment: Computer hardware – Intel® Core™ i7 at 2.90 GHz, 8 GB RAM; software – Microsoft® Windows® 10 Enterprise 64-bit, Microsoft® Visual Studio® 2010, VISA™ version 5.8.

12. Exclude current measurement ranges less than 1 mA.

Maximum Single Measurement Rates (operations per second) for 60 Hz (50 Hz)

A/D Converter Speed (NPLC)	Trigger Origin	Measure to USB	Source Measure to USB	Source Measure Pass/Fail to USB
0.001	Internal	1900 (1800)	1400 (1400)	1400 (1400)
0.01	Internal	1450 (1400)	1200 (1200)	1100 (1100)
0.1	Internal	450 (390)	425 (370)	425 (375)
1.0	Internal	58 (48)	57 (48)	57 (48)

Maximum Measurement Range Change Rate

>7000 per second for >10 µA. When changing to or from a range ≥1 A, maximum rate is >2200/second.

Maximum Source Range Change Rate

>400 per second >10 µA. When changing to or from a range ≥1 A, maximum rate is >190/second.

Maximum Source Function Change Rate

>1000 per second

Command Processing Time

<1 ms. Maximum time required for the output to begin to change after receiving the `smua.source.levelv` or `smua.source.leveli` command.

Triggering and Synchronization Characteristics

Triggering

Trigger In to Trigger Out	0.5 µs
Trigger In to Source Change ¹³	10 µs
Trigger Timer Accuracy	±2 µs
Source Change After LXI Trigger	280 µs

Synchronization

Multi-node Synchronized Source Change ¹³	< 0.5 µs
Single-node Synchronized Source Change ¹³	< 0.5 µs

Notes

13. Fixed source range with no polarity change

Supplemental Information

Programming	<p>Embedded Test Script Processor (TSP®) scripting engine is accessible from any host interface:</p> <ul style="list-style-type: none"> Responds to individual instrument control commands Responds to high-speed test scripts comprised of remote commands and test script language (TSL) statements (for example, branching, looping, and math) Able to execute high-speed test scripts stored in memory without host intervention
Minimum User Memory Available	16 MB (approximately 250,000 lines of TSP code)
Test Script Builder	Integrated development environment for building, running, and managing TSP scripts; includes an instrument console for interactive communication with any TSP-enabled instrument. For information on requirements, refer to the Test Script Builder documentation, available at tek.com/keithley .
Software Interface	Read/write with Microsoft® Visual Basic®, Visual C/C++®, Visual C#®, LabVIEW™, CEC TestPoint™ Data Acquisition Software Package, NI LabWindows™/CVI, and so on.
Reading Buffers	<p>Nonvolatile memory uses dedicated storage areas reserved for measurement data. Reading buffers are arrays of measurement elements. Each element can store the following items:</p> <ul style="list-style-type: none"> Measurement Source setting (at the time the measurement was taken) Measurement status Range information Timestamp <p>Reading buffers can be filled using the front-panel STORE key, and retrieved using the RECALL key or host interface.</p>
Buffer Size, With Timestamp and Source Setting	>60,000 samples
Buffer Size, Without Timestamp and Source Setting	>140,000 samples
System Expansion	The TSP-Link expansion interface allows TSP-enabled instruments to trigger and communicate with each other. See the figure below.

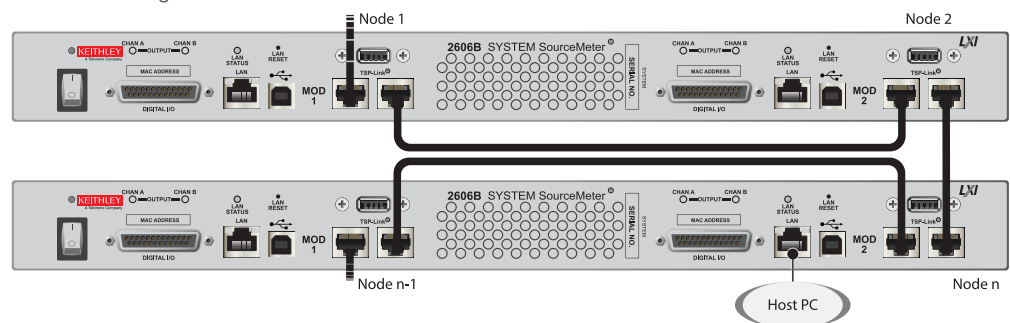

The 2606B has four TSP-Link connectors (two on each module) to make it easier to connect instruments in a sequence.

Once source-measure instruments are interconnected through the TSP-Link expansion interface, a computer can access all of the resources of each source measure instrument through the host interface of any System SourceMeter.

A maximum of 32 TSP-Link nodes can be interconnected. Each source-measure module uses one TSP Link node.

Timing

Timer	Free-running 47-bit counter with 1 MHz clock input. Reset each time instrument power is turned on. If the instrument is not turned off, the timer is automatically reset to zero (0) every four years.
Timestamp	TIMER value is automatically saved when each measurement is triggered
Resolution	1 μ s
Timestamp Accuracy	\pm 100 ppm

General Specifications

Ethernet	RJ-45 connector, LXI version 1.4 Core 2011, 10/100BaseT, Auto-MDIX
LXI compliance	LXI version 1.4 Core 2011
Expansion interface	<p>The TSP-Link® expansion interface allows TSP-enabled instruments to trigger and communicate with each other.</p> <p>Cable Type: Category 5e or higher LAN crossover cable.</p> <p>9.84 ft (3 m) maximum between each TSP-enabled instrument.</p>
USB Control	USB 2.0 Device: USB-TMC488 protocol
USB File System	USB 2.0 Host: Mass storage class device
Power Supply	100 VAC to 240 VAC, 50 Hz or 60 Hz (auto sensing), 425 VA maximum
Cooling	Forced air; front and side intakes and rear exhaust
Warranty	1 year
EMC	Conforms to European Union EMC Directive
Safety	NRTL Listed to UL61010-1, and CSA C22.2 No 61010-1. Conforms with European Union Low Voltage Directive.
Environment	<p>For indoor use only</p> <p>Altitude: Maximum 6562 ft (2000 m) above sea level</p> <p>Operating: 0°C to 50°C, 70% relative humidity up to 35°C. Derate 3% relative humidity/°C, 35°C to 50°C</p> <p>Storage: -25°C to 65°C</p>
Dimensions	Rack Mount: 1.7 in. high \times 19 in. wide \times 26.8 in. deep (44 mm \times 483 mm \times 680 mm)
Weight	13.6 kg (30 lb.)

Digital I/O Interface

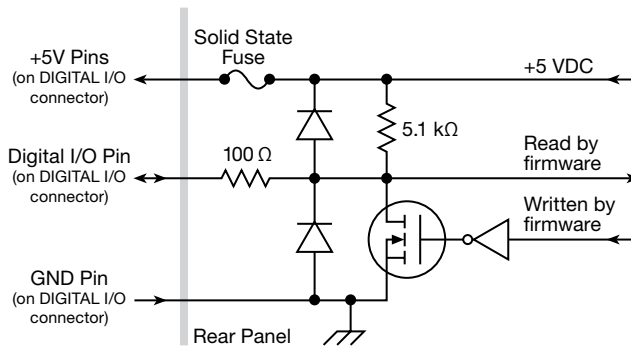

Connector: 25-pin female D

Input/Output Pins: 14 open drain I/O bits

Absolute Maximum Input Voltage: 5.25 V

Absolute Minimum Input Voltage: -0.25 V

Maximum Logic Low Input Voltage: 0.7 V, +850 μ A max

Minimum Logic High Input Voltage: 2.1 V, +570 μ A

Maximum Source Current (flowing out of digital I/O bit): +960 μ A

Maximum Sink Current at Maximum Logic Low Voltage (0.7 V): -5.0 mA

Absolute Maximum Sink Current (flowing into digital I/O pin): -11 mA

5 V Power Supply Pin: Limited to 250 mA, solid-state fuse protected

Output Enable: Active high input pulled down internally to ground with a 10 k Ω resistor; when the output enable input function has been activated, each SourceMeter channel will not turn on unless the output enable pin is driven to >2.1 V (nominal current = 2.1 V / 10 k Ω = 210 μ A).

Ordering Information

2606B

Four-channel System SourceMeter SMU Instrument

Supplied Accessories

Operators and Programming Manuals

CA-180-16	LAN crossover cable, 0.41 m (16 in.) (2 included)
174710700	Shielded CAT5 Crossover Cable for TSP-Link and direct Ethernet connection, 1.5 m (5 ft.)
CA-568	Green and yellow ground cable, 3 m (120 in.)
2600-KIT	Eight-pin custom cable connector, cable housing, and strain relief (4 included)
7709-308A	25-pin D-shell connector kit (for Digital I/O port) (2 included)
4299-13	1U Fixed Rack Mount Kit (Minimum 0.686m (27 inches) rail depth required)
Power Line Cord	Country Dependent
Test Script Builder Software	(Available download from www.tek.com)
LabVIEW Driver	(Available download from www.tek.com)
User's Manual	(Available download from www.tek.com)

Available Accessories

Cables and Connectors

2600-BAN	Banana Test Leads/Adapter Cable.
2600-KIT	Extra screw terminal connector, strain relief, and cover
2600-TRIAX	Phoenix-to-Triax Adapter for 4 wire sensing
7078-TRX-*	3-Slot, Low Noise Triax Cable, 0.3 m–6.1 m. For use with 2600-TRIAX Adapter * = 1, 3, 5, 10, 12, 20 (for 0.3 m, 0.9 m, 1.5 m, 3.0 m, 3.5 m, 6.0 m respectively)
7078-TRX-GND	3-Slot Male Triax to BNC adapter (guard removed)
7709-308A	Digital I/O Connector (model specific)
8606	High Performance Modular Probe Kit. For use with 2600B-BAN

Digital I/O, Trigger Link, and TSP-Link

2600-TLINK	Digital I/O to TLINK Adapter Cable, 1 m
CA-126-1A	Digital I/O and Trigger Cable, 1.5 m
174710700	Shielded CAT5 Crossover Cable for TSP-Link and direct Ethernet connection, 1.5 m (5 ft.)

Available Services

Extended Warranties

2606B-EW	1 Year Factory Warranty extended to 2 years
2606B-3Y-EW	1 Year Factory Warranty extended to 3 years
2606B-5Y-EW	1 Year Factory Warranty extended to 5 years

Calibration Contracts

C/2606B-3Y-STD	3 Calibrations within 3 years
C/2606B-5Y-STD	5 Calibrations within 5 years
C/2606B-3Y-DATA	3 Calibrations within 3 years and includes calibration data before and after adjustment
C/2606B-5Y-DATA	5 Calibrations within 5 years and includes calibration data before and after adjustment
C/2606B-3Y-17025	3 ISO-17025 accredited calibrations within 3 years
C/2606B-5Y-17025	5 ISO-17025 accredited calibrations within 5 years

Warranty Information

Warranty Summary	This section summarizes the warranties of the Series 2606B. For complete warranty information, refer to the Series 2606B Reference Manual. Any portion of the product that is not manufactured by Keithley is not covered by this warranty and Keithley will have no duty to enforce any other manufacturer's warranties.
Hardware Warranty	Keithley Instruments, Inc. warrants the Keithley manufactured portion of the hardware for a period of one year from defects in materials or workmanship; provided that such defect has not been caused by use of the Keithley hardware which is not in accordance with the hardware instructions. The warranty does not apply upon any modification of Keithley hardware made by the customer or operation of the hardware outside the environmental specifications.
Software Warranty	Keithley warrants for the Keithley produced portion of the software or firmware will conform in all material respects with the published specifications for a period of ninety (90) days; provided the software is used on the product for which it is intended in accordance with the software instructions. Keithley does not warrant that operation of the software will be uninterrupted or error-free, or that the software will be adequate for the customer's intended application. The warranty does not apply upon any modification of the software made by the customer.



绿测科技有限公司

广州总部：广州市番禺区陈边村金欧大道83号江潮创意园A栋208室
深圳分公司：深圳市龙华区龙华街道 油松社区东环一路1号耀丰通工业园1-2栋2栋607
南宁分公司：广西自由贸易试验区南宁片区五象大道401号五象航洋城1号楼3519号
广州分公司：广州市南沙区凤凰大道89号中国铁建·凤凰广场B栋1201房
电话：020-2204 2442
传真：020-8067 2851
邮箱：Sales@greentest.com.cn
官网：www.greentest.com.cn



微信视频号



绿测科技订阅号



绿测工场服务号